

Precast Prestressed Segmental Floating Drawspan for Admiral Clarey Bridge



Michael J. Abrahams, P.E.

Senior Vice President
Parsons Brinckerhoff
Quade & Douglas, Inc.
New York, New York



Gary Wilson

Sales Manager
Marine & Heavy Construction
Concrete Technology Corporation
Tacoma, Washington

The use of segmental precast construction techniques resulted in quality, durability and economy in the floating drawspan for this \$84 million design-build project located in Pearl Harbor, Hawaii. The new 4700 ft (1433 m) long bridge connects the "main side" area of the Naval Base at Pearl Harbor with Ford Island, and the drawspan provides a 650 ft (198 m) wide opening for large ships. The fixed trestle is a prestressed concrete girder structure utilizing stay-in-place prestressed deck form panels and supported by prestressed piles. The floating span is a cellular concrete box pontoon, comprising precast panels integrated with cast-in-place concrete. This article provides an overview of the project and describes the design and construction of three 310 x 50 x 17.5 ft (94.5 x 15.2 x 5.3 m) deep hollow concrete sections that were produced in Tacoma, Washington, and integrated at the site into one continuous 930 ft (283.5 m) long floating bridge pontoon.

Ford Island, located at the U.S. Navy's Pearl Harbor Naval Base Hawaii, is often remembered as the site of Battleship Row, and the surprise attack by Japan leading to the United States' entry into World War II. The nearby USS Arizona Memorial is visited daily by thousands of tourists paying their respects to the 2300 Americans who died in that attack, a number of whose remains are entombed in the sunken battleship Arizona.

It is with this important part of American history as a backdrop that the Navy undertook development of

the island to serve as the site of new housing and administrative facilities. The Navy's preferred concept was a low profile bridge to the island that would not obscure the setting of the memorial and the experience of its many visitors, while at the same time providing a convenient vehicle crossing. However, in order to allow large ships to travel around Ford Island, a large movable span was required. The result was a decision to build the world's largest openable span, a floating drawspan that provides a 650 ft (198 m) wide access channel through the bridge (see Fig. 1).



Fig. 1. Aerial view of Pearl Harbor showing Admiral Clarey Bridge. Ford Island is in background with "Battleship Row" and USS Arizona Memorial in upper middle of picture. (Courtesy: Williams Photography of Honolulu.)



Fig. 2. Precast prestressed floating drawspan showing floating section being retracted under fixed bridge spans. (Courtesy: Williams Photography of Honolulu.)

BACKGROUND

Originally called Ford Island Bridge, the structure has since been renamed Admiral Clarey Bridge in honor of Admiral Bernard Clarey, an important U.S. Naval commander in the Pacific Theater during World War II.

Fig. 2 is a view of the openable floating drawspan showing the precast floating section being retracted under the fixed bridge spans. Fig. 3 shows the fixed approach spans.

Ford Island is 450 acres (182 ha) in size and located approximately 4000 ft (1219 m) offshore in Pearl Harbor, the center of the U.S. Navy's Pacific Fleet operations on the island of Oahu in Hawaii (see Fig. 4). While the island is flat, the surrounding area features low hills, enhancing the protected waters of Pearl Harbor.

Access to the island has been limited to ferryboats, as has access to the Arizona Memorial. Just to the north of the ferry route, the new Ford Island Boulevard crossing stretches east for approxi-

mately 6800 ft (2072 m) from Saratoga Boulevard on Ford Island to Kamehameha Highway on the Halawa side. For football fans, Aloha Stadium, where the Aloha Bowl, Hula Bowl and Pro Bowl are played, is located only about 2000 ft (609 m) from this intersection.

The area surrounding the base is highly developed, and housing for Naval personnel is difficult to obtain. In addition, the base itself is highly developed. The large tract of underdeveloped land on Ford Island presented an excellent opportunity to obtain space not only for new housing but also for facilities that the Navy wanted to relocate from other areas. In a creative financing arrangement, the Navy was able to sell two parcels of underused land to the City of Honolulu for \$109 million. These funds were then invested so the principal and interest could be devoted to developing this and other related projects.

The bridge includes a 1000 ft (305 m) long causeway, a 4000 ft (1219 m)

long fixed trestle and a 1035 ft (315.5 m) long movable section that includes the transitions and floating drawspan. The fixed trestle spans utilize prestressed concrete girders supported on prestressed concrete pile bents with cast-in-place concrete caps. The movable section consists of two steel transition spans, one 120 ft (36.6 m) long and the second 250 ft (76.2 m) long, plus a 930 ft (283.5 m) long prestressed concrete floating drawspan. Traffic rides on the central 665 ft (202.7 m) of the floating drawspan with the two ends of the drawspan extending under the transition spans (see Fig. 5).

The fixed spans include a low level section, a sentry house and turnaround area, as well as a high level section to allow a small boat channel. As the small boat channel is the high point of the bridge, it is also the location of the control house for the movable span. It is intended to be opened infrequently, only a few times a year.



Fig. 3. Fixed approach spans comprising continuous prestressed bulb-tee girders and deck panels supported on pile bents and caps, and prestressed piles.

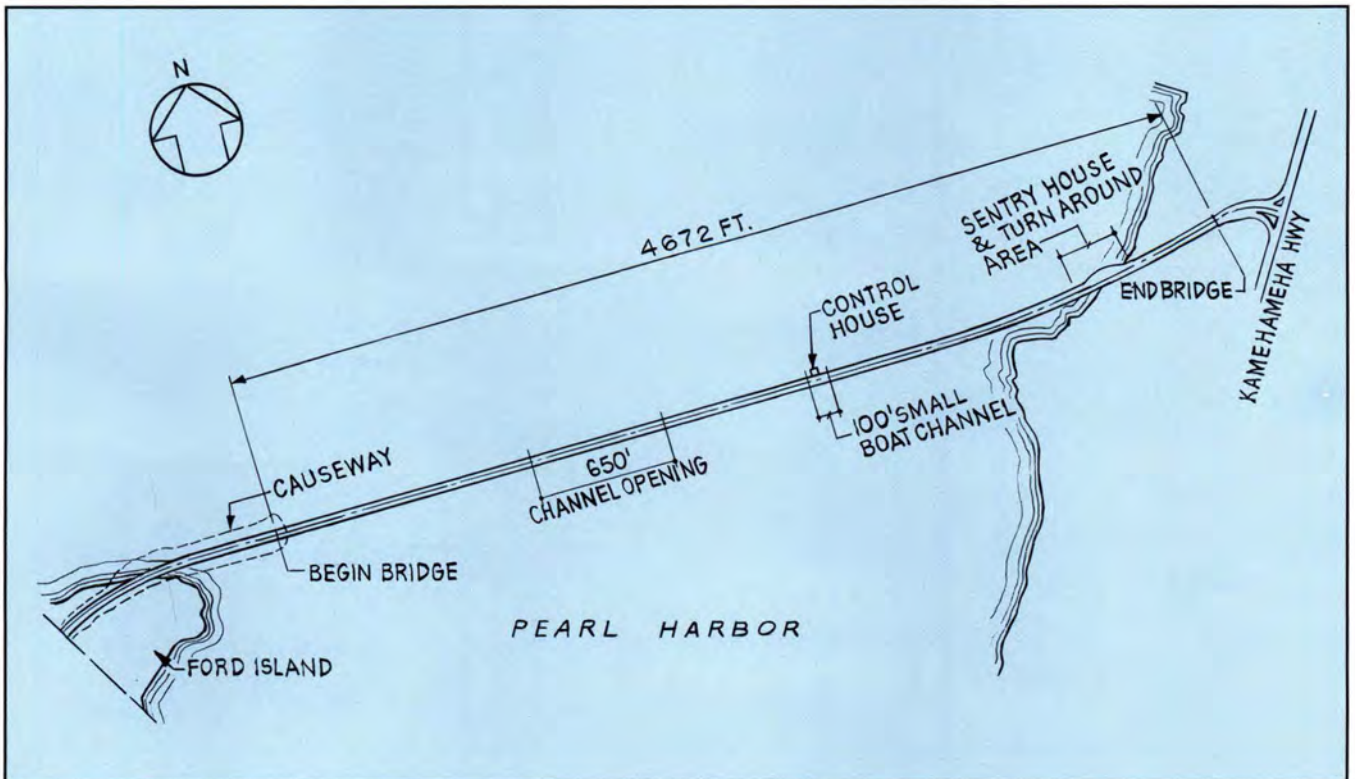

Fig. 4. Site plan showing bridge configuration relative to Ford Island and mainside.

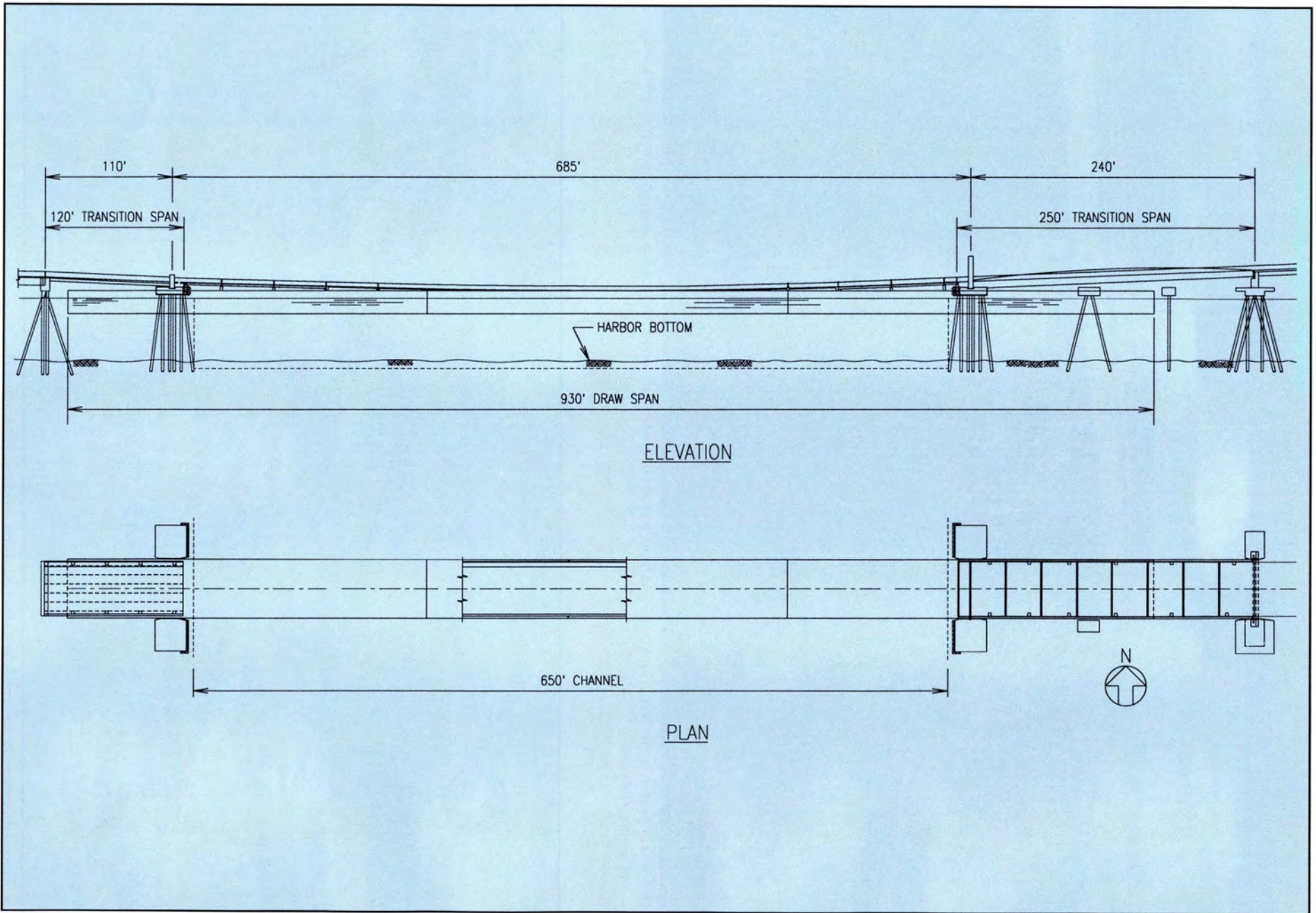
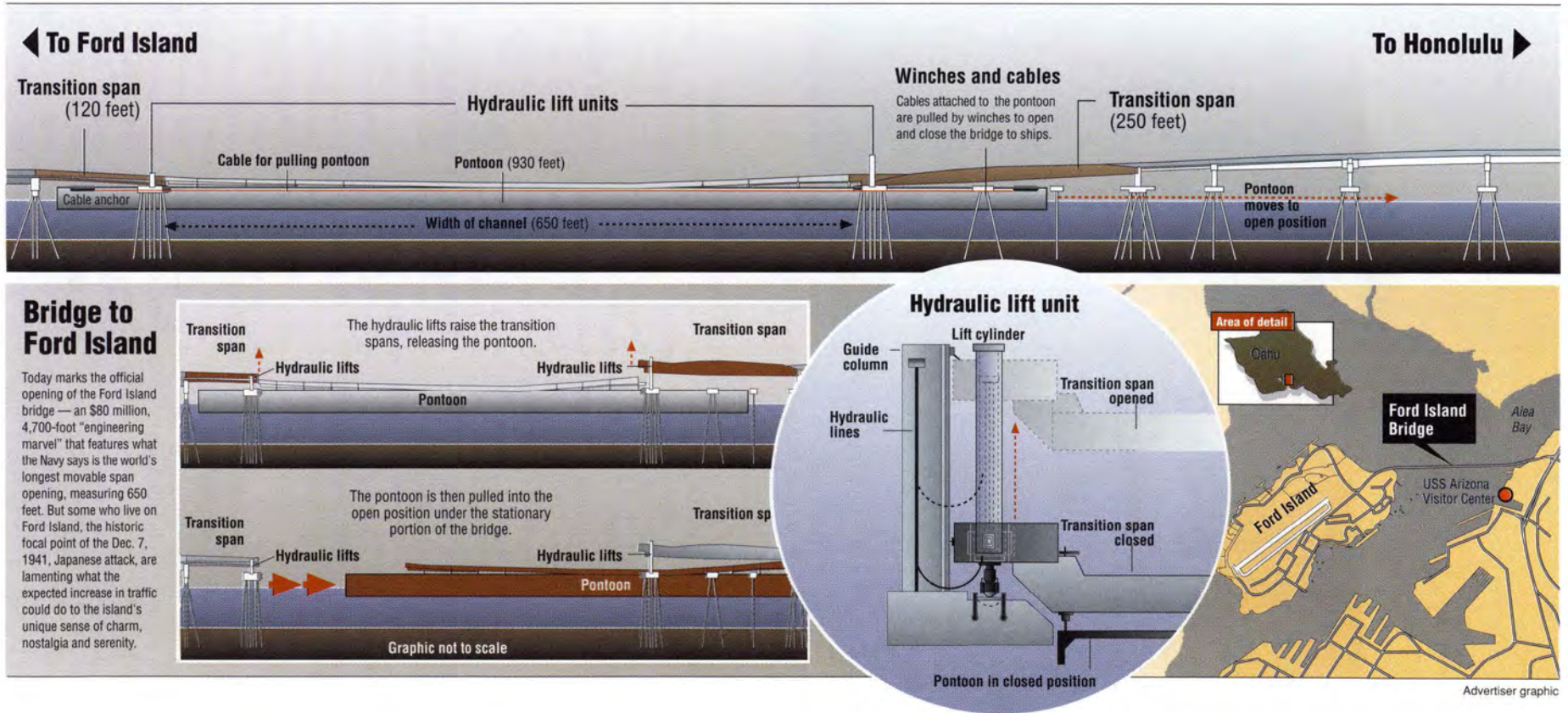

Fig. 5. Elevation and plan of drawspan and transition spans.



99 Fig. 6. Movable section. (Courtesy: *The Honolulu Advertiser*.)

The movable span is designed to be opened or closed within a 25-minute period. This is accomplished by stopping traffic with traffic lights and lowering traffic gates, backed up by traffic barrier gates. The two transition spans are then raised hydraulically and the drawspan is withdrawn or extended using hydraulically powered winches.

The pontoon moves through the water at a speed of 14 in. (355 mm) per second (see Fig. 6). When withdrawn, the pontoon slides under six of the fixed approach spans, and for those spans, straddle type pier bents with transversely post-tensioned caps are used. Figs. 7 and 8 illustrate the configurations of a typical fixed pier and a straddle pier.

THE DESIGN-BUILD APPROACH

Proposal Phase

Prior to the design and construction phase of the project, planning and environmental studies had been completed. Consequently, at the start of the project, an Environmental Impact Statement (EIS) had already been prepared by the Navy, and the alignment and concept of a combination fixed and floating bridge was defined. During the design phase, some adjustments were made to the cross section, alignment and locations of both the movable span and small boat channels.

With the EIS in hand, the Navy solicited statements of qualifications from design-build teams to compete for the opportunity to design and construct the project. Based on these statements, three teams were selected and awarded contracts of \$350,000 each to prepare conceptual and preliminary design documents. These included outline specifications, a design brief and a fixed price proposal to build the bridge in accordance with the EIS and additional design requirements furnished by the Navy. However, the available information did not include a survey, and the limited geotechnical data available were not on the final alignment. As a result, the joint venture invested an additional \$50,000 to conduct probes and borings along the alignment in order to obtain

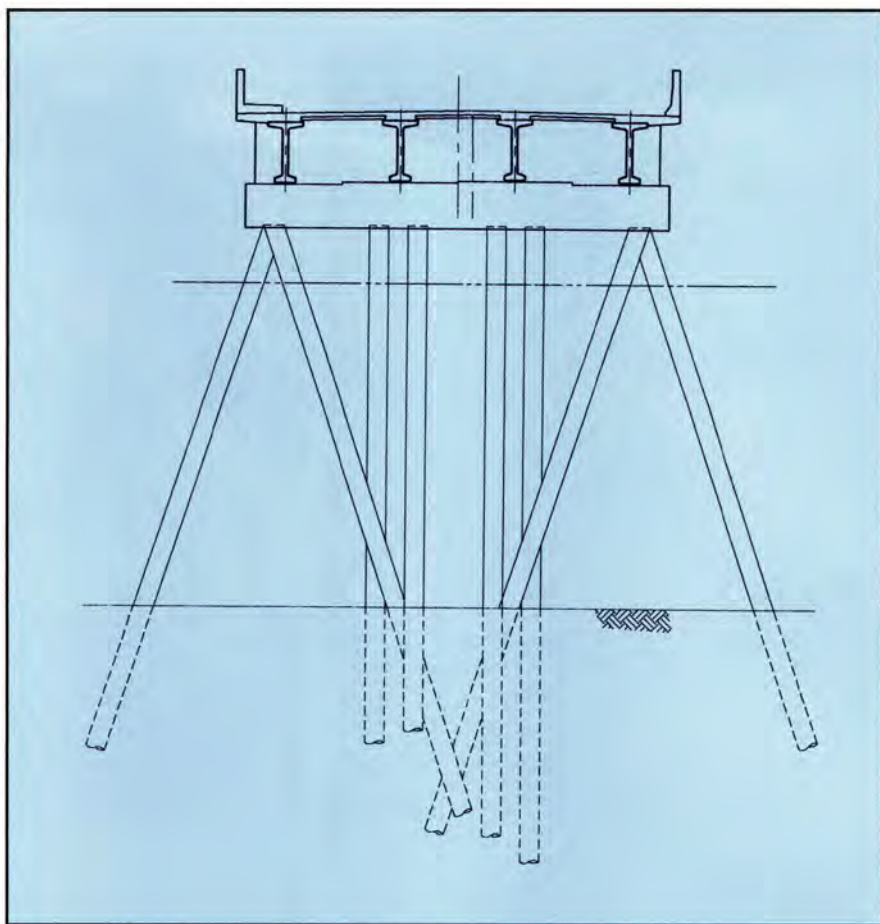

Fig. 7. Typical pile supported pier.

a better definition of the anticipated pile lengths.

On August 19, 1994, after evaluating the three preliminary design submittals, the Navy awarded a design-build contract to the joint venture team of Dillingham-Manson, which comprised Dillingham Construction Pacific, Ltd., of Honolulu, Hawaii, and Manson Construction Company of Seattle, Washington. The joint venture retained the consulting engineering firm of Parsons Brinckerhoff Quade & Douglas, Inc. of Honolulu as its engineer, and the year-long final design phase of the project began.

The bid price of \$67,500,000 to build the bridge was about \$10,000,000 below the Navy's budget and included all of the engineering costs associated with preparation of the final design documents, final borings, survey, shop drawing review, construction consultation, and field inspection and testing. As a result, surplus funds were available to upgrade the bridge during final design for a future three full lanes of traffic rather

than the original two. The value of the concrete pontoon with superstructure was approximately \$9,000,000.

Design Phase

Given the aggressive marine environment and the Navy's desire for high durability and low maintenance, the material specifications received particular attention. In many cases, the Navy required specific provisions to ensure the long-term integrity of the structure. These included the use of 5 percent silica fume by weight of cementitious material in all concrete; a maximum water-cementitious material ratio of 0.38; all prestressed concrete to have zero tension under service loads; pipeline type epoxy coating that is tougher than the epoxy coating commonly applied to reinforcing steel; and concrete cover greater than that required by AASHTO. For example, 3 in. (76 mm) of cover was used for the reinforced concrete bents. Although not required by the Navy, all cement used had a maximum C_3A content of

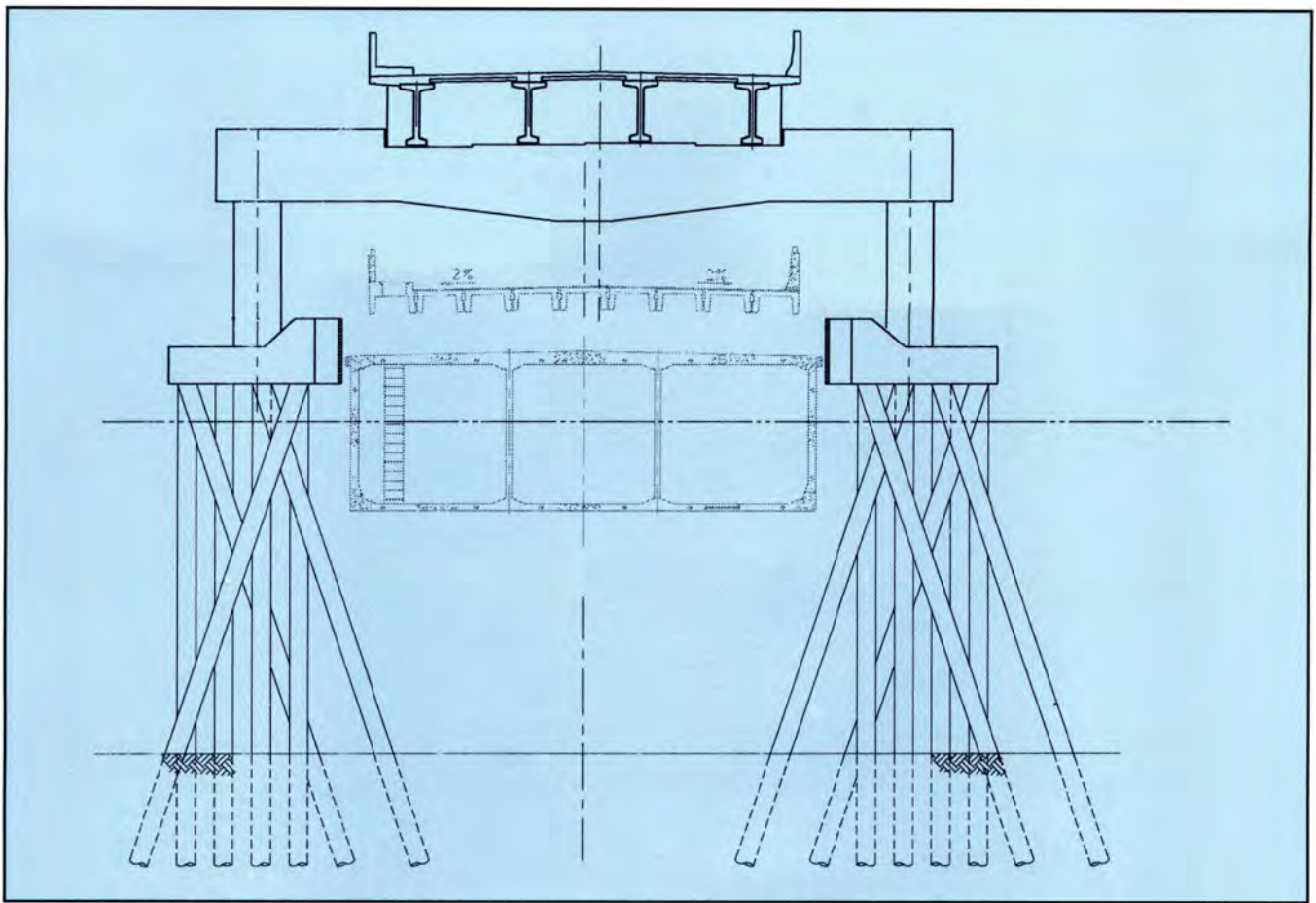

Fig. 8. Straddle pier.

8 percent, as recommended in ACI 201.2R, "Guide to Durable Concrete," for marine exposure.¹

Pile-Supported Piers — The fixed spans extend over both water and land at the Halawa, or mainside, end. Pile-supported piers over the water are founded on 24 in. (609 mm) octagonal prestressed piles, which were produced in Hawaii.

Each pile utilized 7000 psi (48 MPa) design concrete strength, and was released at 4000 psi (28 MPa). The piles contain 24 Grade 270 low-relaxation, 1/2 in. (12.7 mm) diameter strands, with additional mild reinforcing steel added to some of the longer piles where increased ultimate moment capacity was required. The piles were designed using the interaction diagrams developed by Anderson and Moustafa.²

The unbraced length of each pile was determined by L-PILE. For the land based piers, 16 1/2 in. (419 mm) octagonal prestressed concrete piles were used, with a design concrete strength of 7000 psi (48 MPa) and a

release strength of 4000 psi (28 MPa). Each of the 16 1/2 in. (419 mm) piles contained eight 1/2 in. (12.7 mm) diameter strands. The allowable design bearing load was 200 tons (181 t) for the 24 in. (610 mm) piles and 100 tons (91 t) for the 16 1/2 in. (419 mm) piles.

As there were a large number of piles, considerable time and effort were spent in optimizing the design of the pile bents. Seismic forces were determined to be the controlling design condition for most piles, and particular attention was paid to this load case. While the design followed the Strength Design Method of the AASHTO Standard Specifications for Highway Bridges,³ site specific SHAKE analyses were used to determine the soil amplification. This proved to be significant as, in the absence of such studies, a more conservative soil amplification factor might have been used. Based on the more exact SHAKE analysis, a soil amplification factor of 1.0 was demonstrated to be appropriate for most of the pile bents, with a factor of 1.2 used elsewhere.

Prestressed Girder Superstructure

— The fixed prestressed girder spans utilize 124 ft (37.80 m) long Washington State Department of Transportation bulb-tee girder sections with a design strength of 7500 psi (52 MPa) and a release strength of up to 7200 psi (50 MPa). The girders contain up to 64 Grade 270 low-relaxation, 1/2 in. (12.7 mm) diameter strands, and are continuous for live load over four spans.

The span length vs. the center-to-center spacing of the girders was optimized in order to minimize both the number of girders per span and the project cost. A typical girder spacing of 12 ft (3.66 m) was chosen.

The analysis was accomplished using the alternative live load distribution factors found in the AASHTO Guide Specifications for Live Load Distribution,⁴ which have now been incorporated into the AASHTO LRFD Specifications.⁵ This live load distribution was confirmed by finite element analysis of a typical span that was used to demonstrate that intermediate

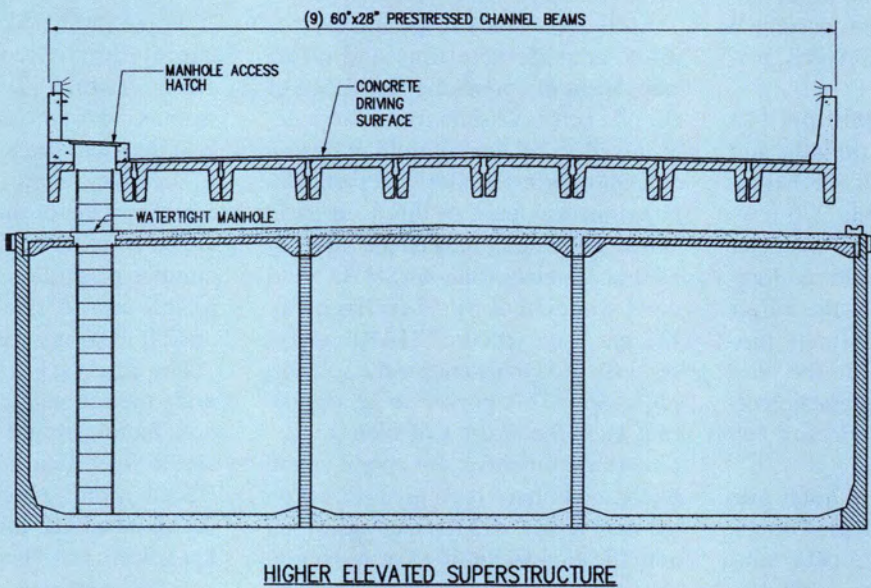
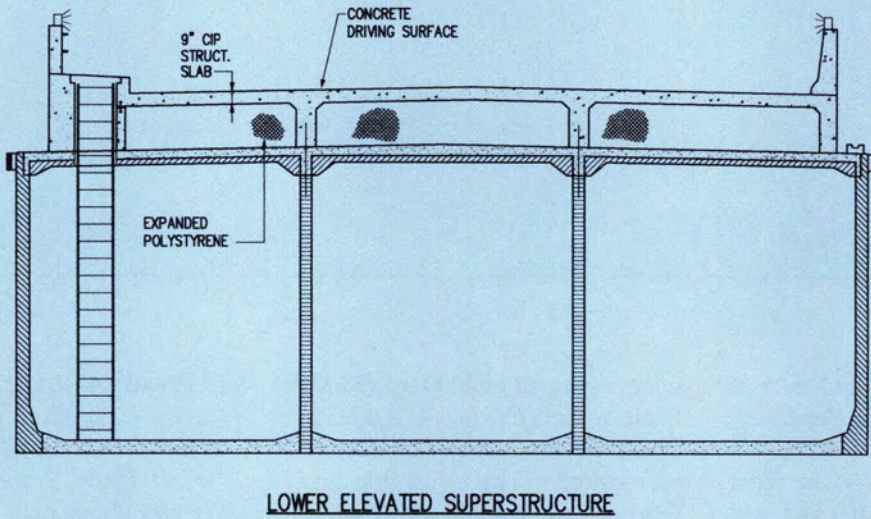
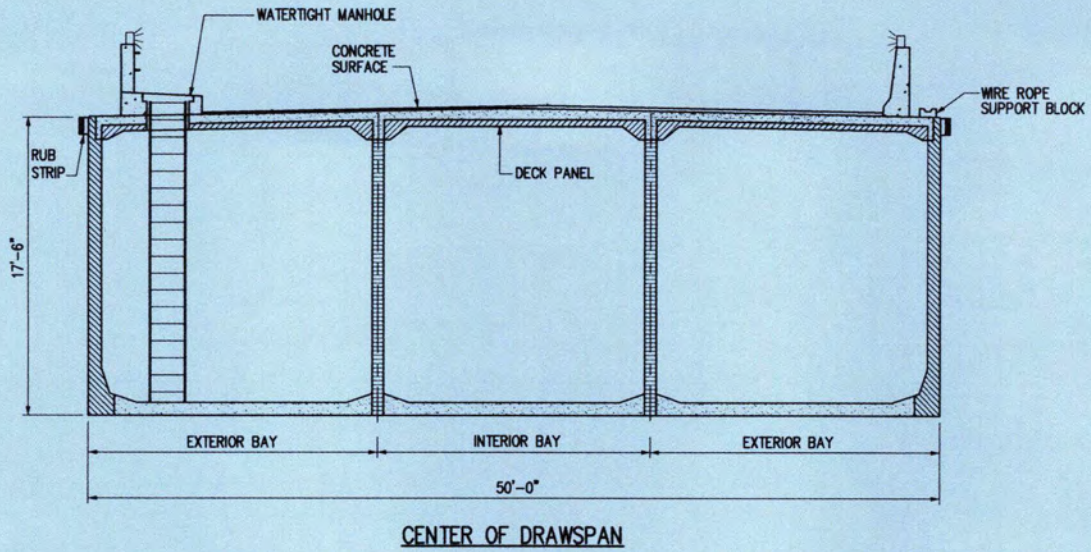

Fig. 9. The three superstructure types.

diaphragms were not required for the 124 ft (37.8 m) long spans.

Prestressed concrete slabs, 4 in. (102 mm) thick, were used to form the bottom of the deck, providing considerable savings as they eliminated the need to form and strip the soffit of the deck over water. The panels were 8 ft (2.4 m) wide and utilized concrete with a design strength of 5000 psi (34 MPa) and a release strength of 4000 psi (28 MPa).

The girder spans were mostly four-span continuous units, with one fixed bearing and three expansion bearings. The spans were made continuous with mild steel reinforcement in the cast-in-place deck. To optimize the design of the pile bents, restrainer keys were added so that all bents would be engaged for longitudinal seismic motion, thus allowing an equal distribution of longitudinal seismic forces.

Floating Drawspan — The drawspan is made up of three 310 ft (94.5 m) long floating concrete modules, bolted together to provide a 930 ft (283.5 m) long unit. The pontoon modules were constructed using a mixture of precast and cast-in-place concrete and they combine reinforced, precast/prestressed and cast-in-place post-tensioned concrete. Each module is divided into 21 watertight cells by longitudinal and transverse bulkheads. The pontoon was designed for both live loads and environmental loads such as waves, wind and current, as well as the accidental flooding of any two cells due to ship collision. Each 310 ft (94.5 m) floating module displaces about 5500 tons (5000 t).

The pontoon walls and diaphragms are precast, as is the soffit of the pontoon deck. The remainder of the pontoon is made of cast-in-place concrete for the bottom slab, wall closures, and upper thickness of the deck. The deck panels are 4 in. (102 mm) thick and contain Grade 270 low-relaxation, 1/2 in. (12.7 mm) diameter strands at approximately 4 in. (102 mm) on center. The precast walls and diaphragms were fabricated with conventionally reinforced concrete. The outer walls were designed to meet the requirements of ACI 350, "Environmental Engineering Concrete Structures,"⁶ as



Fig. 10. Pontoon end wall form ready for concrete.



Fig. 11. Precast wall panels stockpiled and ready for erection.

this specification was developed for watertight structures.

The inner walls were designed following the AASHTO Specifications for ultimate strength under the design condition of internal flooding of one cell and no water in the adjacent cell. Consideration was given to providing vertical post-tensioning in the outer walls, but this was not used as there was considerable experience with the successful performance of reinforced concrete pontoon walls constructed with the same aggregates that were proposed for this project.

The entire pontoon was post-tensioned longitudinally to a level that would maintain it in constant compression under service load conditions and exceed the ultimate moment de-

mand under the flooded condition mentioned above. The pontoon bottom slab was post-tensioned transversely to resist the service loads and to keep it in constant compression. Another purpose of the transverse post-tensioning was to provide a compression force across all below-water construction joints.

The roadway surface of the floating drawspan was designed with an elevated structure consisting of both precast and cast-in-place concrete. The lower elevations of the roadway were of cast-in-place concrete, and where the thickness increased to exceed 10 in. (254 mm), tapered blocks of expanded polystyrene were added to minimize the amount of concrete and the weight of the deck.

For the more elevated portions, cast-in-place reinforced concrete piers were used with precast pretensioned channel slabs and a concrete topping. Fig. 9 shows the three different superstructure types. In order to avoid deck participation on the overall bending and creep shortening of the pontoon, relief joints were introduced into the pontoon deck structure. All of the pontoon concrete has a design strength of 6000 psi (41 MPa).

The pontoon design was based on the AASHTO Specifications, including an HS-20 live load as well as the effects of wind, current and waves. Wave loads were based on a previous study that determined the maximum wind speed and wave height for a 100-year return period. This information was used to conduct a dynamic analysis of the floating drawspan restrained by the elastic stiffness of the pile supported bents.

The three pontoon sections were tensioned together with high strength bolts, protected in a special grease to allow for future disassembly if required. The joint bolts were designed to match the force of the longitudinal prestress in the pontoons.

Because only the central 665 ft (202.7 m) portion of the pontoon carries the dead load of the concrete roadway, the dead load distribution is not uniform. The tendency of the

drawspan would have been to sag down in the middle, in the shape of a smile. This was counteracted by cambering the pontoons at assembly so that the two end pontoons bent down in the shape of a frown. After deballasting, the cambering proved to be very successful, as the assembled pontoon rides flat in the water.

CONSTRUCTION OF FLOATING SECTIONS

Wide Use of Concrete Floats

The first floating structure built by Concrete Technology Corporation (CTC) was a 375,000 barrel (30,000 metric ton) Liquid Petroleum Gas (LPG) storage facility for Atlantic Richfield Indonesia, Inc. Started on November 14, 1974, and launched on April 25, 1976, it was the largest structure of its kind in the world. The concrete hull displaces 65,000 tons (59,000 t) fully loaded and measures 461 ft long x 136 ft wide x 56.5 ft deep (140.5 x 41.5 x 17.2 m). The project was delivered to the owner as a complete facility including crew quarters for 50 personnel, heliport, and all the equipment for the liquefaction, refrigeration and storage of LPG gas at ARCO's offshore oil field in the Java Sea.⁷

The graving dock at CTC was originally constructed for the floating LPG

barge and was sized accordingly for that structure. Flooding and dewatering of the dock required the installation and removal of steel sheet piles, which functioned as a gate at the shoreline. In anticipation of future floating structure projects, an operable gate was fabricated in 1979 and fitted to a watertight seal at the open end of the dock.

This gate consists of a floating concrete caisson with pumps and chambers for ballast water. In each launch cycle of the graving dock, it is deballasted and floated out of the way to allow clear passage between Blair Waterway and the interior of the dock. A 60 ton (54 t) overhead gantry crane was also installed, which services the full length and width of the graving dock.

Since 1979, CTC has produced floating concrete structures for many projects, including the Admiral Clarey Bridge. They have been used as barge loading docks, ferry terminals, breakwaters, floating dolphins, boathouses, fuel floats, moorage structures for large boats, and sinkable caissons. The floats have included a wide range of sizes from small modular units to large single-piece structures.

One interesting 1980 project in Ketchikan, Alaska, consisted of small 4.5 ft wide x 6 ft deep (1.4 x 1.8 m) modules post-tensioned into a 23 ft (7.0 m) wide ladder-shaped breakwater with a total length of 1080 lineal ft (329.2 m).

Another interesting 1982 project in Valdez, Alaska, consisted of two 100 ft wide x 30 ft deep x 350 ft long (30.5 x 9.1 x 106.7 m) floats that were post-tensioned together, at the jobsite, into one 700 ft (213.4 m) long floating cargo dock.⁸

The construction of floats at CTC has been variously hollow or foam filled, cast-in-place or precast segmental, and post-tensioned or conventionally reinforced. The method of construction is determined by the designer according to the size of the structure, its intended use and other design and economic factors.

Precast Segmental vs. Cast-in-Place Construction

Most of CTC's larger pontoons have been hollow, based on precast segmen-

Table 1. Pontoon and precast concrete quantities.

Pontoon quantities (including superstructure).

Material	Quantity	
Concrete volume	7100 cu yd	5400 m ³
Prestressing steel	675,000 lbs	306000 kg
Epoxy coated mild reinforcing steel	1,300,000 lbs	590000 kg
Total weight	15,500 tons	14000 t

Precast concrete quantities.

Product	Components	Quantity		Typical weight	
Exterior walls	84	29,438 sq ft	2735 m ²	60,000 lbs	27000 kg
Interior walls	144	42,847 sq ft	3981 m ²	32,000 lbs	14500 kg
Haunched deck panels	342	39,767 sq ft	3694 m ²	6000 lbs	2700 kg
28 in. channel beams	54	2030 lineal ft	619 m	35,000 lbs	16000 kg
24 in. octagonal piles	412	46,700 lineal ft	14,240 m	60,000 lbs	27,200 kg
16 1/2 in. octagonal piles	74	4500 lineal ft	1370 m	15,000 lbs	6800 kg
Prestressed I-girders	130	15,650 lineal ft	4770 m	130,000 lbs	59,000 kg
Prestressed bridge deck panels	1456	99,400 lineal ft	30,300 m	4000 lbs	1800 kg

tal construction, post-tensioned prior to launching. This construction method is ideally suited to CTC's facilities in Tacoma, Washington. The modern pre-stressed concrete plant located adjacent to the graving dock in Puget Sound allows rapid, economical production of high quality precast components and close coordination with assembly activities in the dock. The graving dock connects to a major waterway in the Port of Tacoma with direct, deep water access to the Pacific Ocean.

Large concrete floating structures, like the Admiral Clarey Bridge drawspan, can be constructed using either cast-in-place or precast segmental techniques. Cast-in-place construction consists of the traditional forming and pouring methods used in all types of heavy construction at a jobsite. Precast segmental construction makes use of both cast-in-place and precast construction methods, drawing on the technical and economic advantages of each technique.

Floating structures, with a modular and repetitive configuration, provide the classic precasting opportunity for multiple reuses of the concrete formwork. Precasting the walls in segments reduces forming costs and the finished pieces are nearly identical, easing fit-up and assembly in the graving dock.⁹

The walls are cast with the exterior face down on a vibrating steel form. This provides a smooth, dense exterior surface with a minimum of patching or sacking of bugholes required. The surface is more durable than that of a vertically poured cast-in-place wall. As the surface that will be placed in contact with sea water, it contributes to the superior durability of the structure.

Dimensional control of wall thicknesses is more easily attained with horizontally poured precast concrete than with vertically cast-in-place concrete. Bulging of forms is not a problem and the thickness of the walls is therefore very uniform. This has important implications for the flotation tolerances (list and trim) of the finished structure. In addition to exterior dimensions, the locations of reinforcing steel and other embedded items are controlled more closely. There is high confidence that the clear cover



Fig. 12. Erected interior walls showing doorway openings and projected reinforcing bar around edges.

over the reinforcing steel will be as specified.

Adequate consolidation of the concrete around the post-tensioning anchors is always an important safety and structural concern. A rock pocket or void near an anchor may lead to a compression failure during stressing operations. With these anchors securely placed in the bottom of the precast wall form, there is minimal risk of poor consolidation. Fig. 10 illustrates the congestion of reinforcing steel, post-tensioning anchors and bolt sleeves in the precast end walls. Confidence of good consolidation around the anchors in cast-in-place walls is not as great.

Another advantage of precasting the walls is that, if one of them fails quality control inspection, it can be rejected prior to being incorporated into the structure. If a cast-in-place wall fails inspection, the area must be removed using demolition techniques that are expensive and time consuming.

Precast components can be cured overnight with heat, which has been shown by Pfeifer et al. to result in greater long-term durability and better resistance to chloride penetration than typical cast-in-place curing methods.^{10,11}

The method of combining precast and cast-in-place techniques allows an opportunity to compress the construction schedule. Starting early and working ahead with a stockpile of precast components minimizes construction

time in the graving dock (see Fig. 11). In addition, work is more easily continued in the plant during inclement weather.

Precasting the Components

Precasting of the various types of components was scheduled to proceed concurrently. This allowed assembly in the graving dock on a moving front. The Admiral Clarey Bridge pontoons have precast interior walls, exterior walls, and haunched deck panels. The elevated portions of the superstructure are framed with precast channel beams. Table 1 lists the precast elements and overall pontoon quantities. All elements were cast in rigid steel forms designed to meet PCI dimensional tolerances. Deck elements are prestressed and wall panels are conventionally reinforced.

Interior Walls — The 7 in. (177 mm) thick interior walls are of two basic types (longitudinal and transverse) with minor variations. One longitudinal wall in each bay has a watertight steel door to allow personnel access into the adjacent cell. Each doorway was pressure tested to the full hydrostatic head of a cell prior to placement in the wall form.

The vertical edges of each wall segment have projecting reinforcing bar hairpins for integration into the cast-in-place pilasters. The bottom edge is perforated with sleeves to accommodate the post-tensioning duct and continuous mild reinforcing steel in the

cast-in-place keel slab. The top edge has projecting reinforcing bars to tie the walls into the cast-in-place deck topping (see Fig. 12).

Field bending of the projecting bars was not allowed, so the side forms were designed to allow their removal over the pre-bent bars. Special care in handling the pipeline epoxy coated reinforcing bars was necessary to avoid damage to the coating. For all interior and exterior walls, the concrete finish of the formed surfaces is smooth except for construction joint locations around the edges, which have a retarded, exposed aggregate surface. Unformed surfaces were floated and the construction joint locations were given a raked finish.

The forms were tented and the walls were heated overnight to provide accelerated curing. The next day, after the panels were removed from the forms, laitance was cleaned from retarded areas and the exposed reinforcing bars were cleaned of concrete spatter. The panels were stockpiled on level wood dunnage with the projecting reinforcing bars covered with tarps to shield them from ultraviolet radiation.

Exterior Walls — The exterior longitudinal wall panels are basically all the same, with left and right variations and shorter panels at the pontoon ends. These panels are haunched at the bottom to provide more embedment for the transverse post-tensioning anchors and to mate with the haunched profile of the keel slab. The central portion of the panels is 10 in. (254 mm) thick, and the top edge has a 5 in. (127 mm) notch, which allows room for a cast-in-place closure to integrate the pre-stressed deck panels.

Fig. 13 shows erected panels and the threaded reinforcing bar couplers that were employed in the panel top edges to eliminate interference of projecting reinforcing bars with placement of the deck panels. These panels were cast with the exterior face down, and the haunch and notch were formed from above with hanging forms. The longitudinal post-tensioning duct was tied in place with the joints sealed against leakage of mortar. The duct projected from the panel edges for later splicing in the cast-in-place pilaster area.



Fig. 13. Erected corner cell. Note reinforcing bar couplers at top of exterior wall at left.

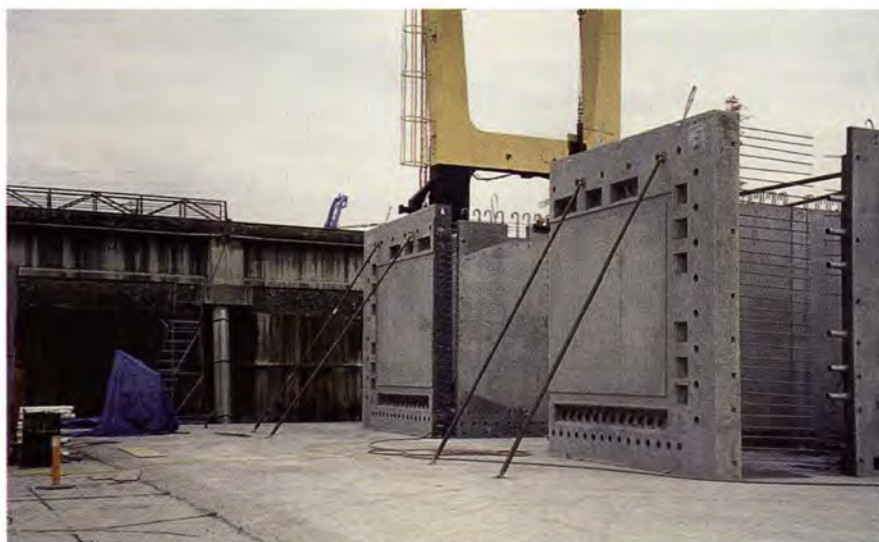

Fig. 14. Erected end walls showing post-tensioning blockouts and integration bolt sleeves.



Fig. 15. Stockpiled haunched deck panels.



Fig. 16. Assembly of precast components in the graving dock.

End Walls — The end walls are unique and contain the embedded anchors for all of the longitudinal post-tensioning. These were cast with the outside face down like the other exterior walls. Reinforcing bars projected from the inside face for integration with massive cast-in-place buttresses at the ends of the pontoons. At the integration ends (both ends of Pontoon B and one end for each of Pontoons A

and C), there are 5 in. (127 mm) diameter sleeves for the 3 in. (76 mm) integration bolts. In addition, the panels have shear keys for the pontoon end-to-end grout joints and continuous recesses at the perimeter to accommodate the 3½ in. (88 mm) wide rubber grout seal (see Fig. 14).

Haunched Decks — The haunched deck panels were produced on a flat stressing bed with a built-up soffit

form in the shape of the haunch. All surfaces except the soffit received a roughened finish for future construction joints or grout keys (see Fig. 15). Inserts were embedded in the bottoms to be used as hangers for the interior piping.

Channel Beams — The channel beams are a standard member produced at CTC for use as bridge beams and pier deck panels. They are cast in a long form with movable bulkheads that are adjusted for the required beam length. The form is also adjustable in width according to the required span/load combination. Projecting reinforcing bars for barriers in the exterior beams were terminated at the deck level with threaded couplers to prevent damage during the ocean tow, and to avoid interference with the steel transition spans that would be loaded on top of the pontoons for the delivery voyage.

Assembly in the Graving Dock

While precasting of the components was under way, the graving dock was being prepared for the construction of the pontoons. A new superflat overlay

Fig. 17. Interior pilaster with post-tensioning ducts spliced and reinforcing bars tied.



Fig. 18. Cell floor (keel slab) after pouring and finishing.



was poured on the existing floor to ensure that the keel slabs would be in plane and of uniform thickness. Drainage was installed to keep the area as dry as possible during inclement weather. Temporary utilities were installed and a field office was established for the production staff. Full scale testing of a wall pilaster pour was performed in order to ensure the success of the forming and concrete pumping method.

Consideration was given to constructing and launching the pontoons in one, two or three different cycles. Many factors were at play including the jobsite schedule and the available weather windows for safe towing across the ocean. It was finally decided to produce Pontoon B first, launch it, and then follow with Pontoons A and C in a second cycle.

Construction of each pontoon started at one end and proceeded with the walls and keel slab, one bay at a time, to the other end. Straightness of the assembled pontoon is critical to the proper operation of the drawspan. Over the 930 ft (283.5 m) final length, a tolerance of plus or minus $\frac{1}{4}$ in. (6.4 mm) was specified. To ensure dimensional accuracy, a surveyor was first employed to layout the wall locations on the graving dock floor. The walls were then placed directly on the floor in their proper location and securely braced (see Fig. 16).

The panel erection crew was followed by the pilaster crew who spliced the post-tensioning ducts in the exterior wall and tied the pilaster reinforcing bars into place for the interior and exterior pilasters (see Fig. 17). Splicing of the oval shaped ducts required special techniques to ensure mortar-tightness and to strengthen the non-cylindrical shape for pressures encountered during concrete pumping.

The forms were then placed and the pilasters were pumped full from the bottom. The specifications required a non-corroding material for the form crossties, so fiberglass rods were used and jacked hydraulically to the proper tension to resist the concrete pumping pressures.

When the first bay of wall panels and pilasters was complete, a bond



Fig. 19. Pontoon B under construction in the graving dock.



Fig. 20. Erecting haunched deck panels used as stay-in-place forms for the pontoon top slab.

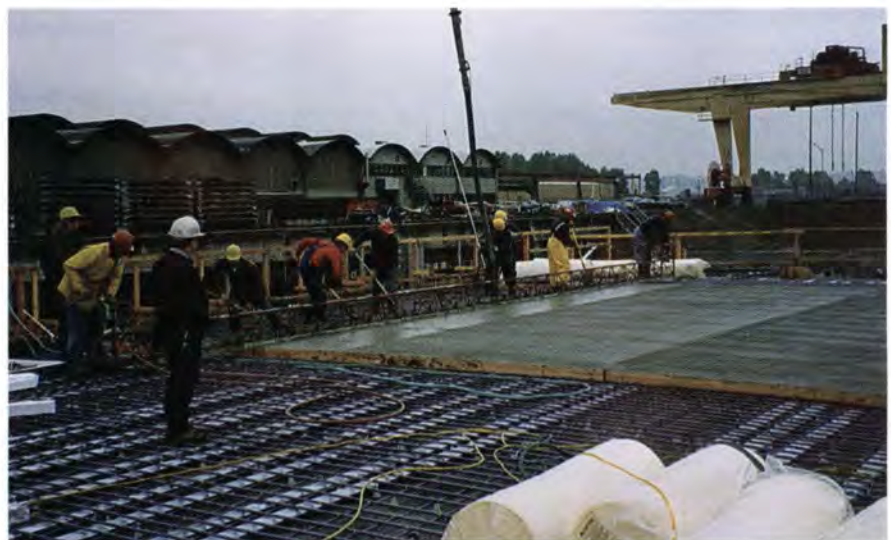

Fig. 21. Casting the pontoon top slab.



Fig. 22. Pushing post-tensioning strand into the keel ducts.



Fig. 23. Erecting channel beams for the elevated superstructure on the pontoon.



Fig. 24. Pouring a silica fume concrete overlay on the channel beams and the 9 in. (229 mm) roadway slab.

breaker was applied to the graving dock floor and the reinforcing bars and post-tensioning duct were placed for the keel slab. Special attention was given to tying the empty duct down securely in order to keep it from floating up during concrete placing operations. Concrete was placed from a standard bucket and consolidated and finished using traditional flatwork techniques (see Fig. 18). The haunched edges at the cell perimeter were formed with elevated screed rails attached to the sides of the precast walls.

Construction proceeded to the end of the pontoon, and as the walls and floor of each bay were completed, erection of the prestressed haunched deck panels began. Installation of bilge piping and water level sensors was coordinated with deck installation, as was pre-positioning of materials and equipment in the cells, which would be used later during integration of the pontoon modules.

Placement of the reinforcing steel and post-tensioning materials for the cast-in-place deck topping followed. The massive buttresses at the ends of the modules were formed with custom steel forms and poured with concrete. Placement of the concrete for the cast-in-place deck topping completed the basic "box," ready for post-tensioning and the superstructure (see Figs. 19, 20 and 21).

Post-tensioning

As the cast-in-place concrete areas were being completed and the concrete was approaching the specified design strength, the post-tensioning strand was being installed in the embedded tendon ducts. Longitudinal tendons are located in the deck, sides and keel; transverse tendons are located in the keel and end walls. Fig. 22 shows workmen pushing strands into the duct from one end.

When the concrete reached the specified strength, the strands in each tendon were stressed with hydraulic rams and then locked off with wedges at each post-tensioning anchor. Stressing was generally necessary from only one end due to the mild curvature of the tendons near the anchors.

After the strands were stressed, each tendon was grouted by pumping a cement/micro silica mixture from one end until a uniform flow streamed from a vent at the other end. The vent and injection port were then capped off and the blockouts at each anchorage were patched with non-shrink grout.

Superstructure

As described earlier, the concrete pontoon superstructure is of two different designs. Near the ends, the elevated roadway consists of channel beam bridge elements that continue downhill until the height of the roadway above the pontoon is no longer sufficient to accommodate the structural depth. At this point, the roadway becomes a structural cast-in-place slab that is formed over the deck of the pontoon on top of tapered polystyrene billets. The polystyrene is preshaped to follow the required profile of the roadway and to provide the forming for the vertical support walls that carry the loads into the pontoon walls below. This construction was held back from the mating ends of each pontoon to be completed in the field after pontoon integration.

The sequence of construction was to place the abutment walls for the channel beams, place the channel beams and pour the end diaphragms, then pour the finished driving surface, continuing from the thin overlay on the channel beam structure to the 9 in. (229 mm) thick structural slab (see Figs. 23 and 24).

Final Details and Launching

Prior to launching, each pontoon module was completed by bolting required accessories in place, such as cleats and the bridge bearing assemblies. Continuous rub strips were bolted along the sides of each module. Neoprene sheets were bonded to the central portions of the end walls on Pontoon B. A 3 1/2 in. wide (89 mm) perimeter grout seal was also attached to both ends of Pontoon B.

Rubber “donut” gaskets were bonded around each integration bolt hole to seal out seawater and grout during the integration procedure. Tem-



Fig. 25. Pontoon B ready for launching.



Fig. 26. Maneuvering the pontoon into Puget Sound.



Fig. 27. Pontoon under tow to Hawaii behind a bargeload of prestressed girders. Note 250 ft (76.2 m) transition span riding “piggy back” on pontoon. (Courtesy: Crowley Marine Services. Photo by Lou VanDemark.)



Fig. 28. Completed bridge.



Fig. 29. Completed bridge looking east.

porary stoppers were placed inside and outside each integration bolt hole as double insurance that seawater would not accidentally flood the end compartments. Fig. 25 shows the depth markings that were painted on each corner to indicate the pontoon draft at "liftoff."

The launch days at CTC were exciting. Family, friends and other interested people gathered to watch the sequence of events. As the crew went through the carefully planned and timed procedures of flooding the graving dock and removing the gate, interest peaked as the water level rose close to the design waterline of the pontoons.

Wagers were made on the exact time of liftoff. Unlike the launching of a ship from a shipway, events progress slowly in the graving dock because the launch cycle follows the daily tidal cycle of Puget Sound. Eventually, the tide rose high enough to lift the modules off the graving dock floor, and a tug boat maneuvered them out to temporary moorage in the waterway (see Fig. 26).

The pontoon modules remained at CTC for a couple of weeks while each cell was carefully inspected and final outfitting was done. Then, they were towed away for loading onto an oceangoing barge for the trip to Hawaii (see Fig. 27).

Figs. 28 and 29 show views of the completed bridge.

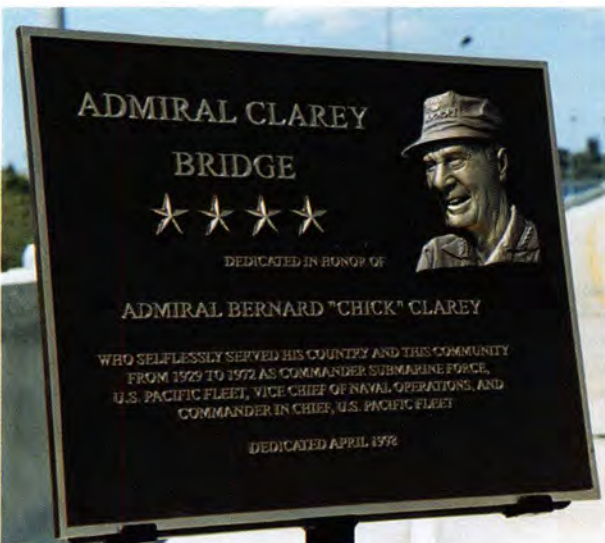

Fig. 30. Bridge dedication plaque honoring Admiral Bernard Clarey. (Courtesy: United States Navy.)



Fig. 31. Bridge dedication ceremony was held on April 15, 1998. Plaque was subsequently mounted at bridge abutment. The three people in foreground next to plaque are Rear Admiral Steven S. Clarey, U.S. Navy (Retired)(partially obscured by the plaque, he is the son of Admiral Bernard Clarey), Mrs. Bernard Clarey, and U.S. Senator Daniel Inouye. (Courtesy: United States Navy.)



Fig. 32. Aerial view of completed bridge showing USS Arizona Memorial in left foreground. (Courtesy: Williams Photography of Honolulu.)

CONCLUDING REMARKS

After a quarter of a century of planning, the Ford Island ferry fleet was retired and the Admiral Clarey Bridge was opened to traffic ahead of schedule. Ground had been broken on January 10, 1996. On April 15, 1998, the bridge was dedicated to Admiral Bernard "Chick" Clarey, an important

Pacific Fleet commander during World War II (see Figs. 30 and 31).

Over the past several decades, concrete floating structures have compiled a good track record in their various uses, including bridge structures. For this project, a floating structure provided the ideal solution for an opening wide enough to accommodate aircraft carriers, and low enough to meet the

aesthetic requirements of the area. Precast segmental construction, together with post-tensioning, offers many advantages for this type of structure, and it has proven itself again in a high quality, economical pontoon for the new Admiral Clarey Bridge. The new bridge is a fitting landmark in this scenic and historic setting (see Fig. 32).

CREDITS

Owner: United States Navy

Designers:

- Parsons Brinckerhoff Quade & Douglas, Inc., New York, New York, Honolulu, Hawaii - Prime Designer
- Moffatt & Nichol Engineers, Santa Ana, California - Fixed Spans
- Makai Ocean Engineering, Kailua, Hawaii - Hydrodynamic Analysis
- Edward K. Noda & Associates, Honolulu, Hawaii - Ocean Engineering and Permits

- Control Point Engineering and Surveying, Honolulu, Hawaii - Survey

Contractor: Dillingham-Manson, a joint venture of:

- Dillingham Construction Pacific, Ltd., Honolulu, Hawaii
- Manson Construction Company, Seattle, Washington

Precast Concrete Manufacturers:

- Concrete Technology Corporation, Tacoma, Washington - pontoons and I-Girders
- Hawaiian Dredging Construction Co., Honolulu, Hawaii - Piling and Bridge Deck Panels

REFERENCES

1. ACI Committee 201, "Guide to Durable Concrete (ACI 201.2R-92)," American Concrete Institute, Farmington Hills, MI, 1992.
2. Anderson, A. R., and Moustafa, S. E., "Ultimate Strength of Prestressed Piles and Columns," *ACI Journal*, V. 67, No. 8, August 1970, pp. 620-635.
3. AASHTO, *Standard Specifications for Highway Bridges*, 15th Edition, American Association of State Highway and Transportation Officials, Washington, D.C., 1992.
4. AASHTO, *Guide Specifications for Distribution of Loads for Highway Bridges*, American Association of State Highway and Transportation Officials, Washington, D.C., 1994.
5. AASHTO, *LRF Bridge Design Specifications*, First Edition, American Association of State Highway and Transportation Officials, Washington, D.C., 1994.
6. ACI Committee 350, "Environmental Engineering Concrete Structures (ACI 350R-89)," American Concrete Institute, Farmington Hills, MI, 1989.
7. Anderson, Arthur A., "World's Largest Prestressed LPG Vessel," *PCI JOURNAL*, V. 22, No. 1, January-February 1977, pp. 12-31.
8. "Floating Concrete Container Terminal at Valdez, Alaska," *Concrete Construction*, February 1983.
9. ACI Committee 357, "State-of-the-Art Report on Barge-Like Concrete Structures (ACI 357.2R-88)," American Concrete Institute, Farmington Hills, MI, 1988.
10. Pfeifer, D. W., Landgren, J. R., and Zoob, A., "Protective Systems for New Prestressed and Substructure Concrete," FHWA Final Report No. FHWA/RD-86/193, Federal Highway Administration, Washington, D.C., April 1987, 126 pp.
11. Pfeifer, D. W., Sherman, M. R., and McDonald, D. B., "Durability Aspects of Precast Prestressed Concrete — Part 2: Chloride Permeability Study," *PCI JOURNAL*, V. 41, No. 4, July-August 1996, pp. 76-95.